

Ava Rek

Sof marketing — shovqin, yolg'on va illyuziyalarsiz strategiya.

Faqat haqiqat, tajriba va natija.

AVAREK:
Biznesni tizimli rivojlantirish va
masshtablashtirish agentligi.

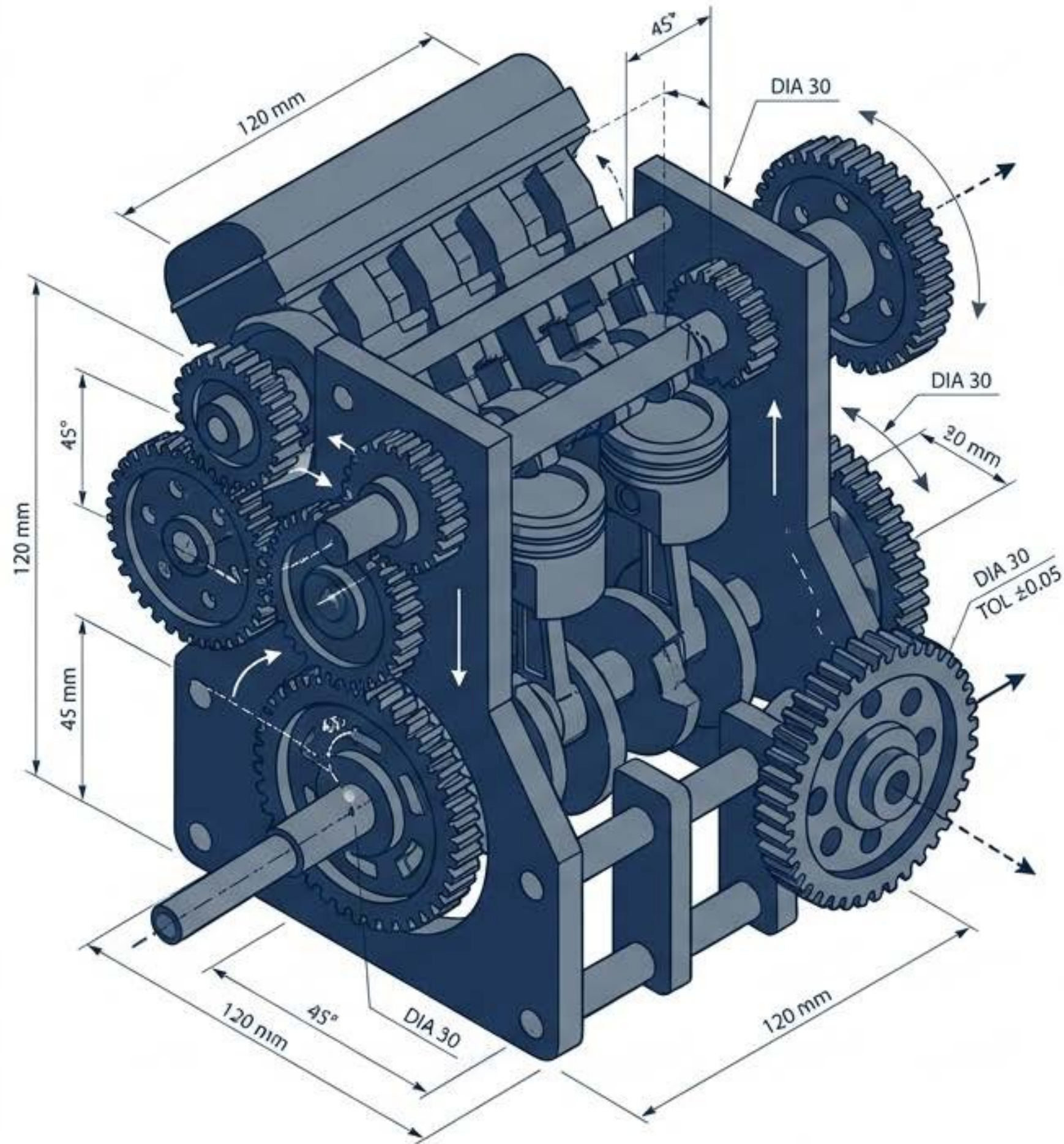

Marketing — bu asboblarni to'plami emas, boshqariladigan tizimdir.

AVAREK — mahalliy va xalqaro bozorlarda kompaniyalarni masshtablashtirishga ixtisoslashgan. Biz marketingni o'lchanadigan natija, savdo o'sishi va biznesning barqaror rivojlanishiga yo'naltirilgan aniq tizim sifatida quramiz.

Yondashuvimizning matematik poydevori

100%

Analitika va audit.

Barcha loyihalar faqat chuqur ma'lumotlarga asoslangan holda boshlanadi.

0

Shablon yechimlar.

Har bir strategiya biznesning o'ziga xosligi uchun individual ishlab chiqiladi.

3

Asosiy fokus. Bizning e'tiborimiz faqat uchta narsada: Savdo o'sishi, Masshtablashtirish, va ROI (Investitsiyalarning qaytishi).

Nima uchun AVAREK? Tizimli yondashuv farqi.

Eski Yondashuv (Boshqalar)

Alohida marketing asboblari va
uzuq-yuluq harakatlar.

Asosiy e'tibor qamrov va layklar kabi
yuzaki metrikalarga qaratiladi.

Faqat trafik jalb qilish bilan
cheklanish.

AVAREK Tizimi (Bizning yondashuv)

Marketing butun boshli,
boshqariladigan tizim sifatida quriladi.

Faqat o'lchanadigan natija va aniq
KPI larga yo'naltirilganlik.

Biznes-maqсадlar va barqaror
masshtablashtirish bilan ishlash.

O'sish dvigatelining ishlash tartibi.

Bizning 6 ta asosiy xizmatimiz izolyatsiya qilingan emas. Ular biznesingizni mahalliy bozordan xalqaro eksportgacha olib chiquvchi yagona ekotizimni tashkil qiladi.

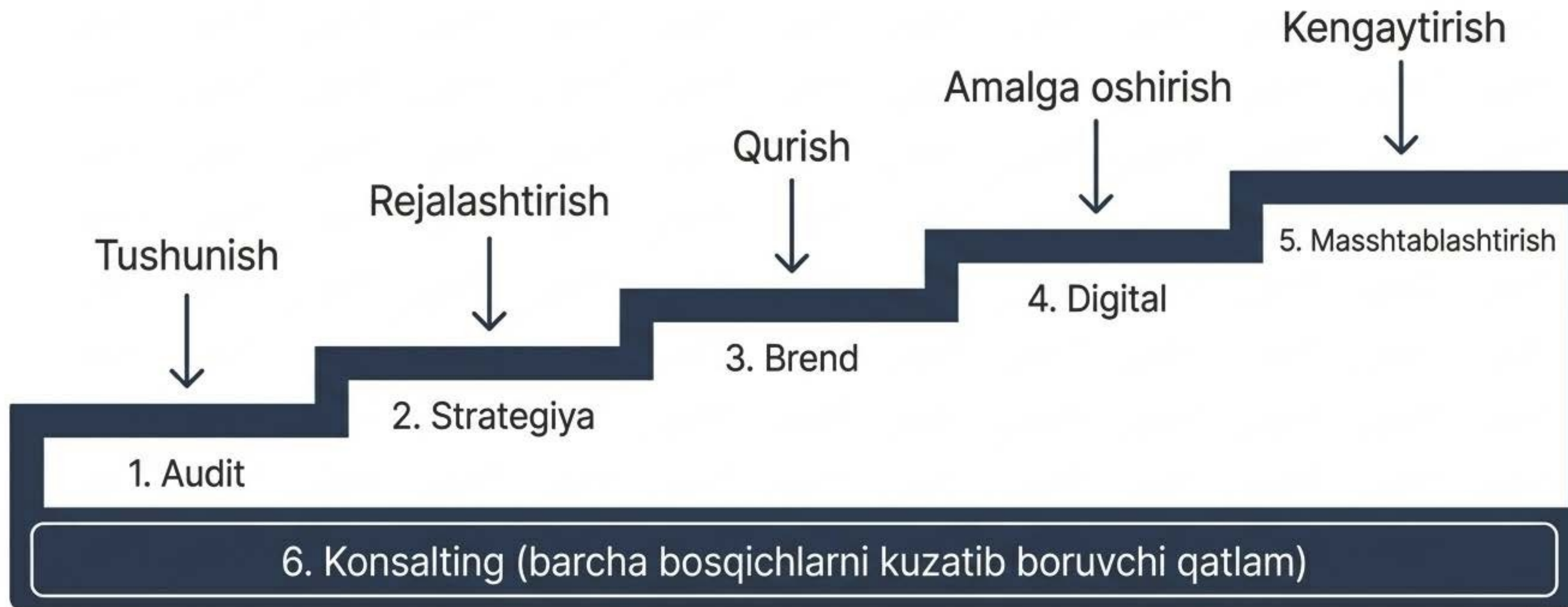

1. Marketing auditi va analitika



Bozor, mahsulot va raqobatchilarni chuqur tahlil qilish.

Joriy marketing kanallarini baholash.

O'sish nuqtalari va uzilishlarni aniqlash.

Natija: Nima ishlayotganini, nima ishlamasligini va qayerga masshtablashtirish kerakligini aniq tushunish.

2. Marketing strategiyasini ishlab chiqish

Pozitsiyalashtirishni shakllantirish.

Maqsadli segmentlarni aniqlash.

Savdo voronkasini qurish.

Sotish va reklama kanallarini rejalashtirish.

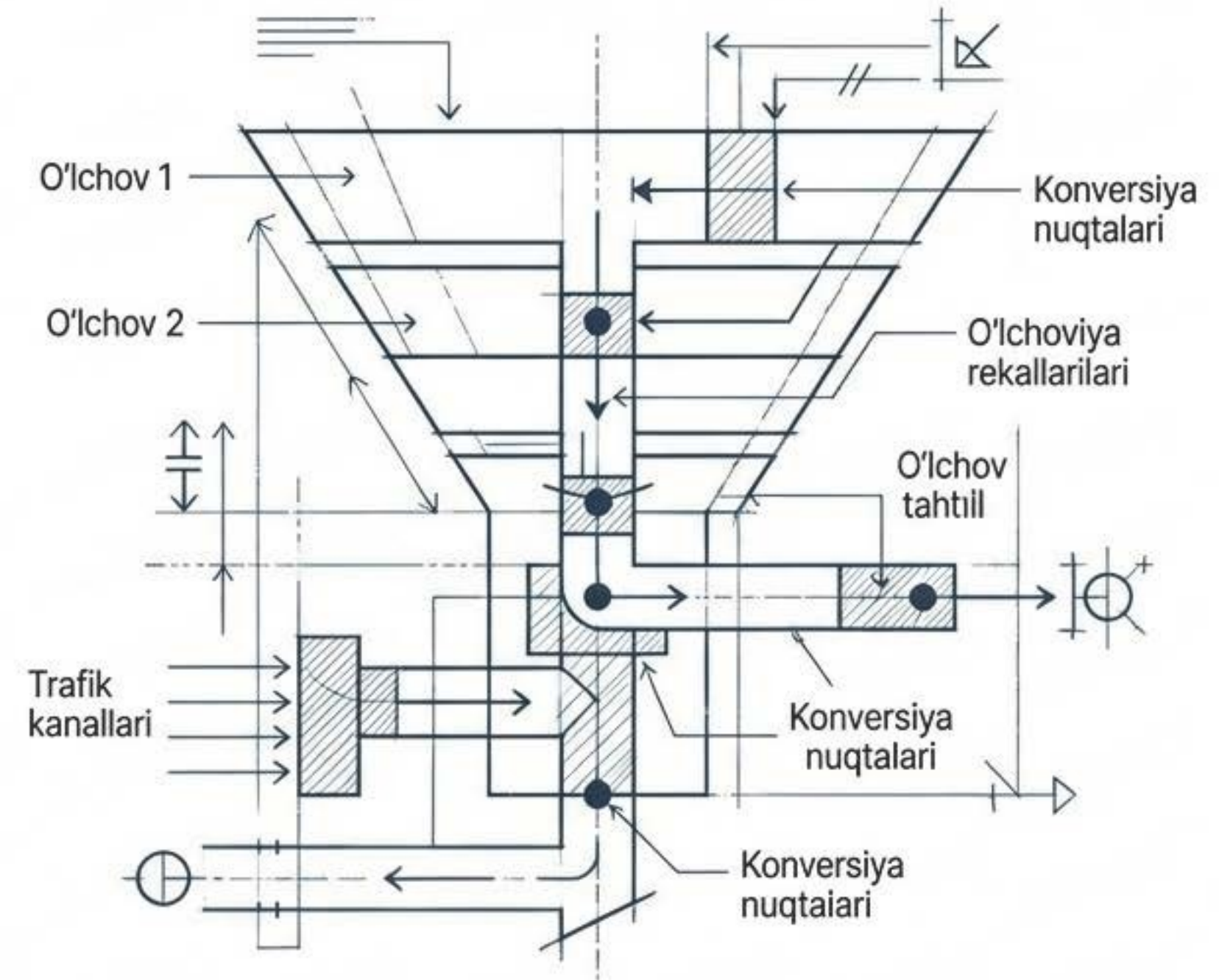

Strategiya o'z ichiga oladi: Maqsadlar, KPI, joriy etish bosqichlari va aniq nazorat nuqtalari.

3. Brendni pozitsiyalashtirish va upakovka

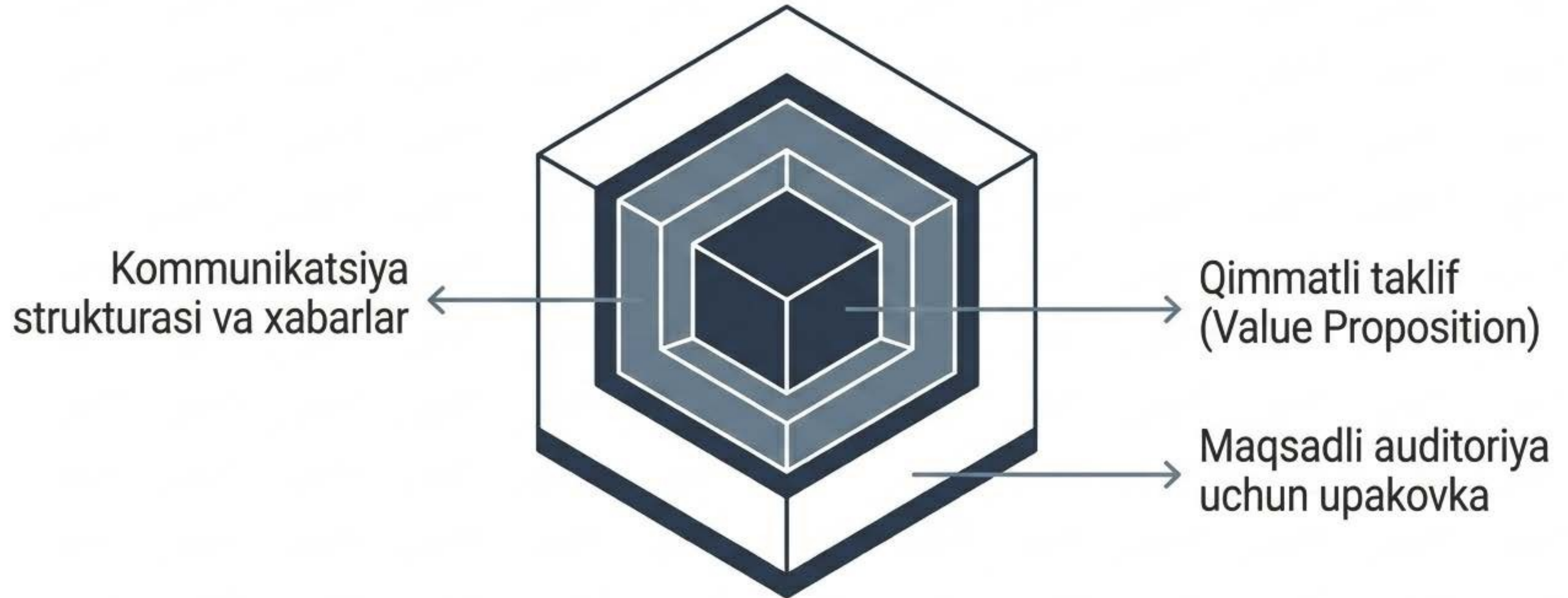

Maqsad: Brendni tushunarli, ajralib turadigan va bozorda raqobatbardosh qilish.

4. Digital-marketing va reklama

1. Onlayn ilgari surish va reklama kampaniyalari.
2. Konversiyaga yo'naltirilgan kreativ konsepsiyalar.

Fokus: Qamrovga emas, aniq natijaga va investiyalarning o'zini oqlashiga (ROI) qaratilgan.

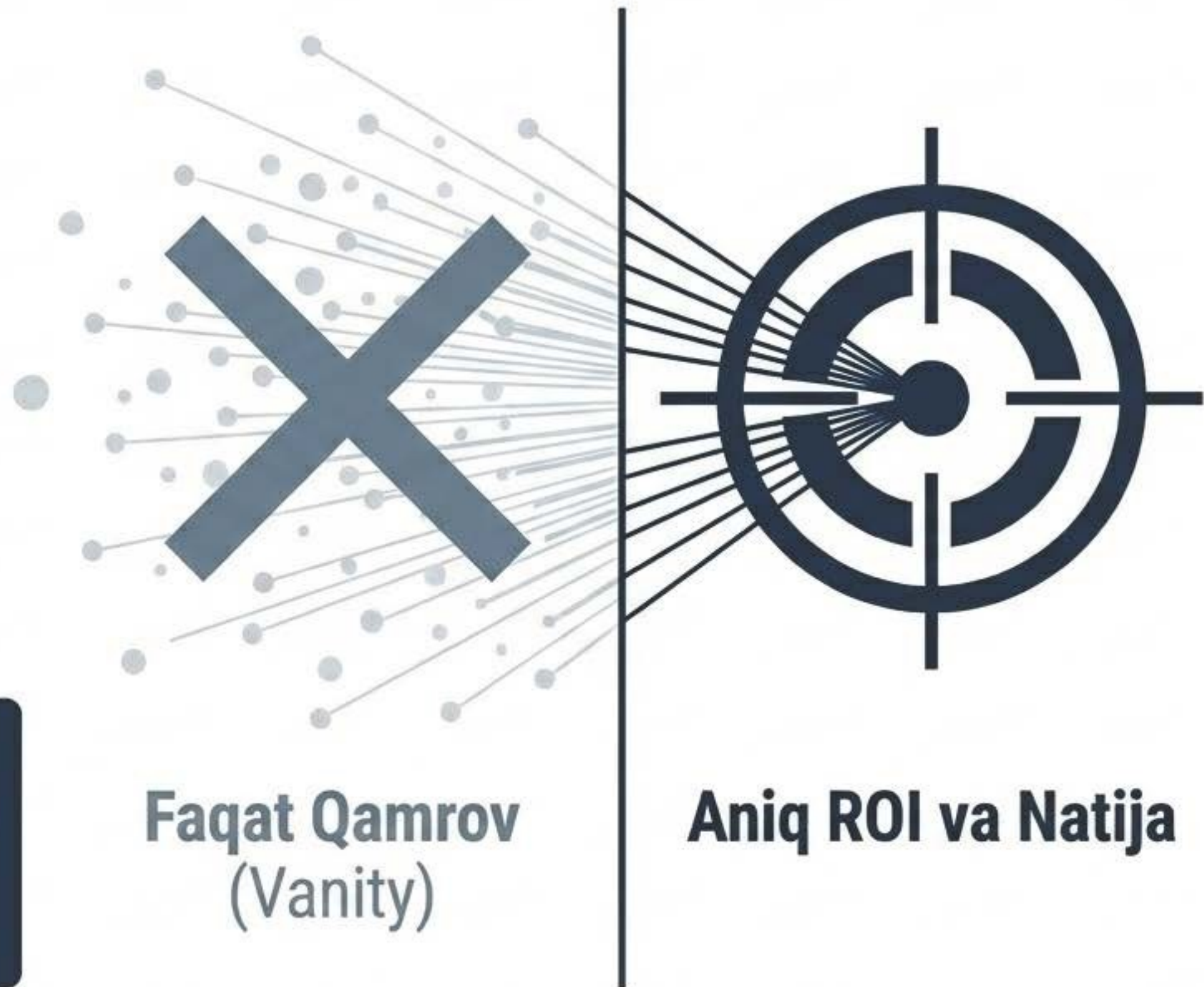

5. Masshtablashtirish va tashqi bozorlarga chiqish (TIF)



Xorijiy bozorlarni chuqur tahlil qilish.



Marketingni mahalliy xususiyatlarga moslashtirish.



Biznes ekspansiyasini strategik qo'llab-quvvatlash.

Kimlar uchun: Eksport, xalqaro hamkorlik va mahalliy bozordan tashqarida o'sishni rejalashtirgan kompaniyalar uchun.



6. Mulkdorlar va jamoalar uchun konsalting

Strategik sessiyalar o'tkazish.



Boshqaruv qarorlarini qo'llab-quvvatlash.

Marketingni biznes-funksiya sifatida sozlash.

Yondashuvimiz: Biz nafaqat asboblarni, balki fikrlash tarzi va marketingni boshqarish tizimi bilan ham ishlaymiz.

AVAREK Bugun – Yagona Ekotizim

Mahalliy va xalqaro loyihalardagi katta tajriba orqali tasdiqlangan barqaror o'sish tsikli.



Kuchli brend qurish vaqti keldi

Biz shunchaki xizmatlarni taklif qilmaymiz — biz aniq natijaga qaratilgan hamkorlikni taklif qilamiz. Tajriba va strategiyalarimizni sizning biznesingiz uchun qanday qo'llashni muhokama qilaylik.

Ava Rek



@avarek_uz



avarek@gmail.com



+998 93 540 45 10



avarek.uz



Loyihangizni muhokama qilish uchun skanerlang.